

SCG10ECX Evaluation Kit - 36-60 V Input, 9-15 V, 4 A Output, 60W

Features

- Peak efficiency: 94.3%
- Full load efficiency: 90.3 %
- 7.5 x 9 mm (0.295 x 0.354 inches)
- Low profile converter: 1.25 mm (2.85 mm inc. PCB)
- Power density: 5100 W/in³ (power converter)
- Fixed voltage conversion ratio from input to output voltage: 1/4 or 1/3
- Selectable switch conductance
- Selectable frequency
- Selectable dead time
- Soft startup into full resistive load

Applications

- Data centers
- Servers
- 48 V Power supply
- Computing
- Intermediate Bus Converter (IBC)

General Description

The EVK_HAS_DIC14_I_A evaluation board is a 60 W, 36-60 V input switched-capacitor power converter that operates as a DC transformer with a fixed voltage conversion ratio of 1/4 or 1/3. The simplified schematic is shown in Figure 2. It features the preliminary SCG10ECX chip, as the core of the switched-capacitor power converter and the Microchip dsPIC33EV64GM103 16-bit 5 V digital signal controller to configure the operation of the power converter.

Efficiency

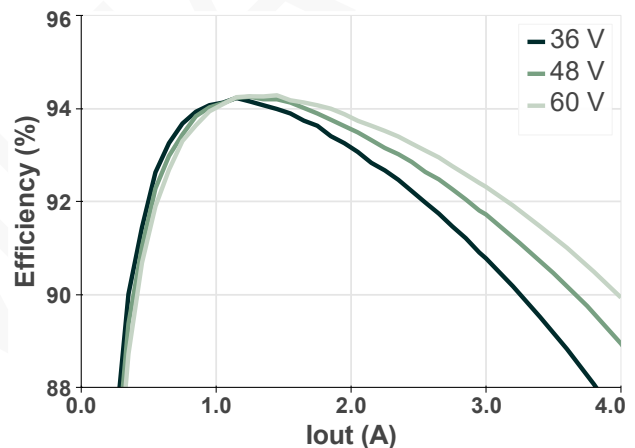

Figure 1. EVK typical efficiency using the 1/4 voltage conversion ratio for different input voltages.

Electrical Characteristics

Symbol	Parameter	Conditions	Min	Typ	Max	Unit
V _{IN}	Input voltage		36	48	60	V
V _{IN,on}	Input UVLO turn on voltage			24		V
V _{OUT,1/4}	Output Voltage	Fixed ratio 1/4 based on V _{IN}	9	12	15	V
V _{OUT,1/3}	Output Voltage	Fixed ratio 1/3 based on V _{IN}	12	16	20	V
I _{OUT}	Continuous output current	400 LFM airflow			3.6	A
f _S	Switching frequency	Set via jumpers		500	1000	kHz
VDD5	Logic power supply		4.75	5	5.25	V
T _C	Junction operating temperature				125	°C

1. Simplified schematic

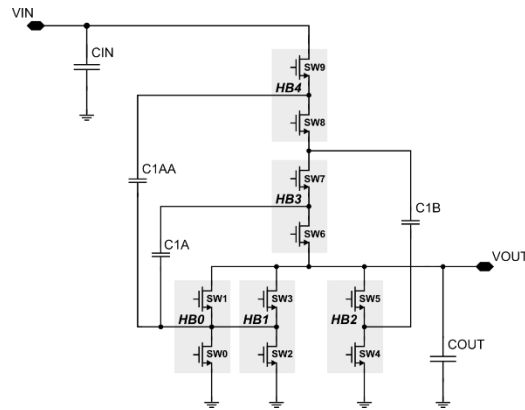

Figure 2. Simplified schematic of the switched-capacitor power converter implemented in the SCG10ECX Evaluation Kit. The highlighted transistors are integrated inside the SCG10ECX chip.

2. Evaluation kit

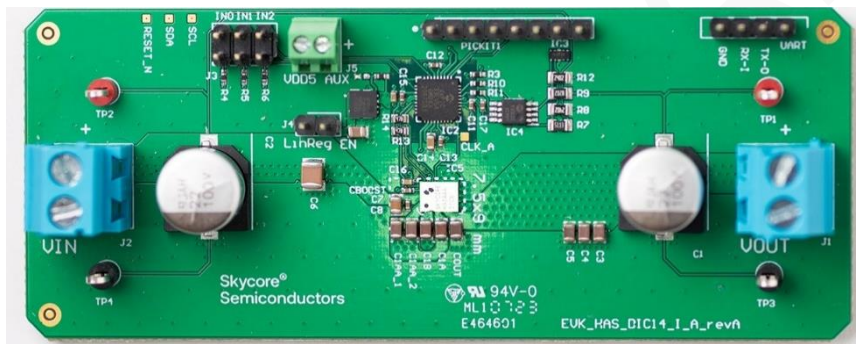

Figure 3. SCG10ECX Evaluation Kit with external power transistors. All the components of the power converter are enclosed in the white rectangle.

3. Bill of materials (Power converter)

Component	Manufacturer	Part number	Value	Amount in parallel
IC	Skycore	SCG10ECX	Preliminary version	1
C1A	Murata	GRM21BC71E106KE11L	22 uF, X7S, 25 V, 1206	1
C1AA	Murata	GRM21BC71H475KE11K	10 uF, X7T, 50 V, 1206	2
C1B	Murata	GRM21BC8YA106ME11K	10 uF, X7T, 50 V, 1206	1
CIN	Murata	GRM32EC72A106KE05K	10 uF, X7S, 100 V, 1210	1
COUT	Murata	GRM21BC71E106KE11L	22 uF, X7S, 25 V, 1206	1
CBST	Murata	GRM155R72A472KA01D	4.7 nF, X7R, 100 V, 0402	1

4. Revision History

Table 1. Revision history description.

Date	Revision	Description
30/06/2023	1	Initial release.

PRELIMINARY

Published by

Skycore ApS
Fruebjergvej 3
2100 Copenhagen, Denmark
Email: info@skycore-semi.com

Document reference

PB_SCG10ECX_DIC14_I_A_EVK_001

Important Notice

Skycore® Semiconductors assumes no responsibility arising from the use of the described specifications and provides no warranty for the use of this product. Before implementation of a product, the recipient of this datasheet must verify any function and other technical information given herein in the actual application. The applications presented herein are used solely for the purpose of illustration and Skycore® Semiconductors makes no warranty or representation that such applications will be suitable without further modification, nor recommends the use of its products for applications that may present a risk to human life due to malfunction or other unintended effects. Skycore® Semiconductors' products are not authorized for use as critical components in life support devices or systems. Skycore® Semiconductors reserves the right to alter this product or its specifications without prior notification.

All referenced product or service names and trademarks are the property of their respective owners.